



# CRAFTING WOODEN LAMPS

24 BRILLIANT  
WEEKEND  
PROJECTS

KEN BURTON





A PENDANT FIXTURE COMBINES WITH SOME BENT WOOD TO FORM A COLORFUL TABLE LAMP.  
BASE: WALNUT, BENT PIECE: ASH

## 8

# WILD FLOWER LAMP

I FOUND THIS GLASS SHADE as I was wandering the lighting aisles of my local home center. I was drawn to the bright color and sleek shape. After looking at it and its cousins (there are a number of different shapes and colors available) I decided it would make a nice table lamp.

What the red thing is, is a glass shade for what is called a mini pendant lamp. Pendant lamps are lighting fixtures meant to dangle from the ceiling by their power cords. Rather than do this, I thought it would be more fun to make a base from which I could suspend the shade. A further search of the lighting section revealed a mini pendant kit containing the light socket and cord. I was glad to find these, as they meant I wouldn't have to invent a means of holding the shade (and the bulb) on my own.

The design itself evolved from a series of sketches. At the time, spring was arriving with its onrush of flowers and leaves. I guess I had these on my mind because the final sketch and design remind me a lot of some flowers I've seen.

As with most lamps, this one has a heavier base attached to a lighter support structure that holds up the lamp parts. The base is turned from thick (16/4) stock although you can easily glue together two or more thinner pieces if you can't find a piece of heavy material. The support is a bent piece made up of thin layers that were glued together over a curved form. This is a process called bent lamination. If you haven't tried bending wood this way, this is a great project with which to start as the bend is fairly gentle and doesn't require much effort to coax into existence.

## Fabrication

Cut three pieces of  $\frac{3}{4}$ "  $\times$  7"  $\times$  27 $\frac{3}{4}$ " MDF, plywood, or particle board to make into the bending form. Draw a 29 $\frac{1}{4}$ " radius arc on one of the pieces with a trammel as shown in the Form Layout. Cut along the curve on the band saw, then sand the the curve smooth. I usually do this on a stationary belt sander. Use the first piece as a pattern and trace the curve onto the other two pieces. Cut and sand them to shape. Screw the three pieces together and do a final sanding to make the curved edges all even with each other. Once the pieces are screwed together, sketch the cutout areas onto one of the faces and cut away these areas on the band saw.

Cut a piece of 6/4 stock so it is 32" long. Joint and plane it, leaving it as thick as possible — you'll cut the bent pieces to width later. Also joint one edge so it is straight and rip the other edge to make it parallel. Rip a series of strips off the edge of the board for bending as shown in Photo 1. Rather than trying to set the fence for such a narrow cut, set up a stop block to the left of the blade as shown to control the thickness of the strips. I used ash for bends on my lamp. Ash bends very well (as does oak). But the bend here is gentle enough that you can probably use any species of wood. Make a test cut from the material you are using and bend it around your form to see if you have the thickness right. I used pieces that were  $\frac{3}{16}$ " thick.

To set the stop (I use the butt end of a feather board), use the rip fence

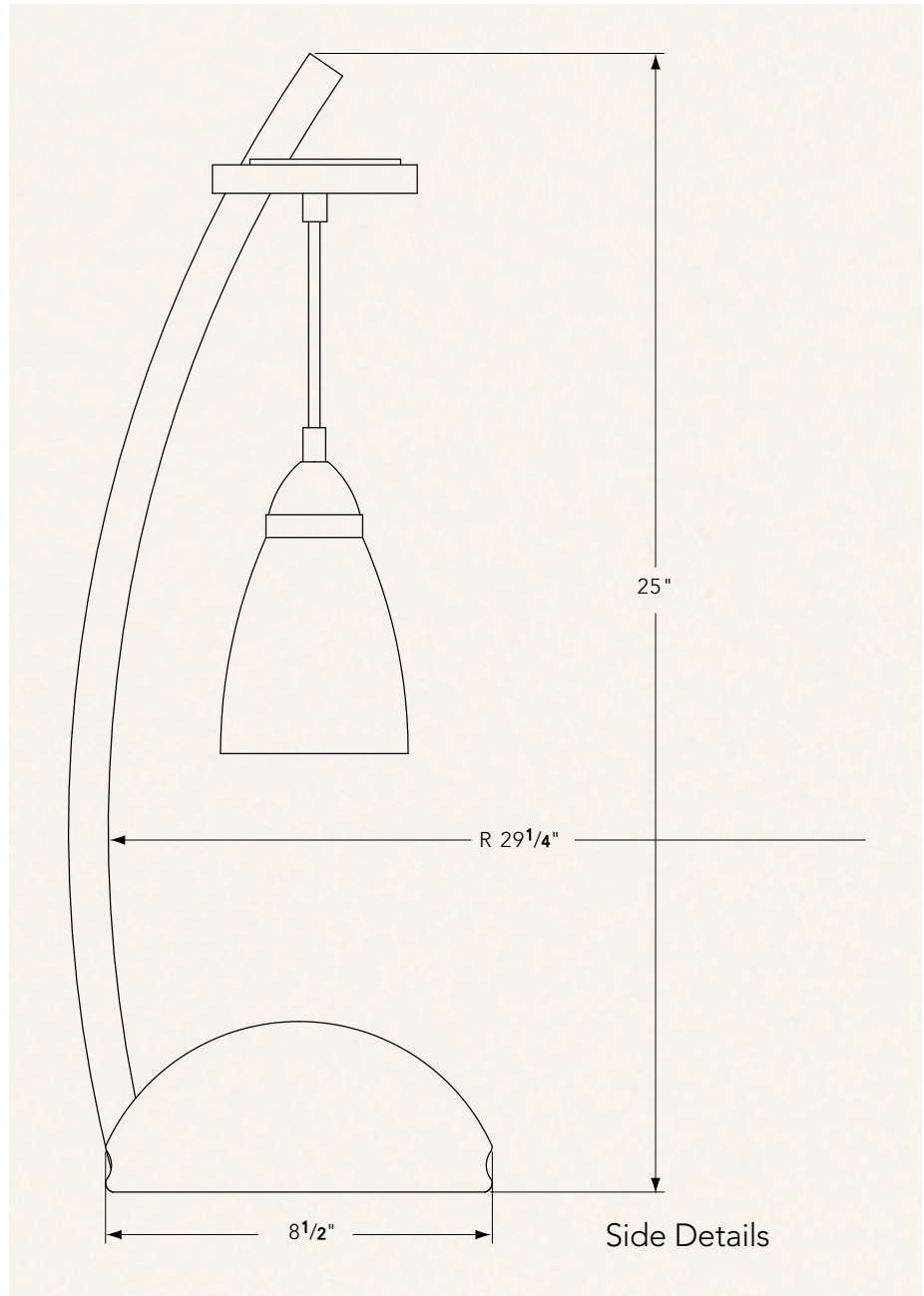

### INCHES (MILLIMETERS)

REFERENCE	QUANTITY	PART	STOCK	THICKNESS (mm)	WIDTH (mm)	LENGTH (mm)
A	5	laminations	ash	$\frac{3}{16}$ (5)	1 $\frac{1}{2}$ (38)	32 (813)
B	1	base	walnut	3 $\frac{3}{4}$ (95)	8 $\frac{1}{2}$ (216)	8 $\frac{1}{2}$ (216)
C	1	disk	walnut	$\frac{5}{8}$ (16)	4 $\frac{1}{2}$ (115)	diameter
D	1	cap	walnut	$\frac{1}{8}$ (3)	3 $\frac{5}{8}$ (92)	diameter
E	1	cover plate	walnut	$\frac{1}{4}$ (6)	3 (76)	diameter

### HARDWARE

#6 x 2" Trimhead Wood Screws (2)  
 #6 x 1 $\frac{1}{4}$ " Brass Wood Screws (2)  
 #4 x  $\frac{1}{2}$ " Brass Wood Screws (3)  
 #6 x 1" Wood Screws (2)  
 Mini Pendant Kit  
 (Westinghouse #70284)  
 2 $\frac{1}{4}$ " Fitter Glass Shade  
 Lamp Cord w/ thumb switch  
 wire nuts (2)

## Form Layout

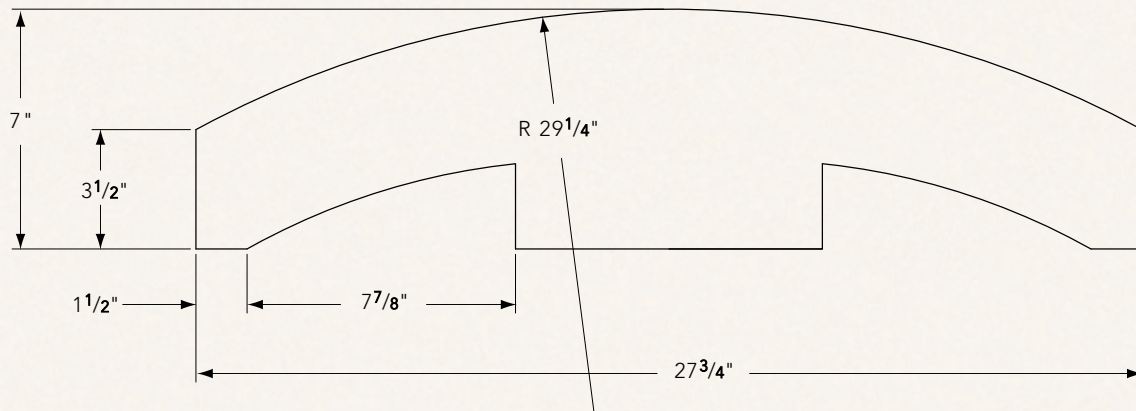

to position the board so the offcut is the thickness you are after. Adjust the stop so it just kisses the left side of the board an inch or two in front of the blade and lock it in place. Make the first cut. Then adjust the rip fence so the left side of the board just kisses the stop. Make the second cut. Keep going, adjusting the fence after each cut until you have enough strips. For each of the lamps, you'll need nine strips, plus a couple extras to help distribute the clamp pressure.

Spread glue on the first three laminations. Add the fourth piece to the stack along with two extra strips (I made my extras from  $\frac{1}{4}$ " plywood) to protect the good pieces from the



**ONE** When cutting strips for bent lamination, keeping the pieces in the order they were cut allows you to glue them up so the grain matches. To help keep things straight, draw a series of diagonal lines across the board so you can put them back in order should things get mixed up.

**TWO** To keep the bent piece from sticking to the form, cover the curved surface with a layer of plastic packing tape before clamping the pieces over it.



**THREE** Jointing a bent piece is very much like jointing a straight piece. Start with the leading edge against the fence and roll the piece through the cut, trying to maintain contact with the fence right over the cutter head.

**FOUR** To cut a bent piece, push it past the blade with a sort of a rolling motion, keeping the section being cut in contact with the table right at the front of the blade.

**FIVE** Guide the bent piece along the fence as you rout the groove for the cord. Like with the table saw cut, roll the piece as you push it past the bit, trying to keep it in contact with the table right where the bit is cutting.

clamps. Bend the stack over the form starting in the middle and working your way out as shown in Photo 2.

Once the glue dries, remove the clamps and scrape away the excess glue. Joint one side of the bent piece to make it straight and square to the convex face as shown in Photo 3.

Once you have established one straight edge, make the second side parallel to it by running the bent piece through the table saw as shown in Photo 4. Set the fence to leave the piece as wide as possible while still cleaning up the rough edge.

Chuck a  $\frac{3}{8}$ " straight bit in your table-mounted router and rout a  $\frac{1}{4}$ "-deep groove down the center of the convex side of the bend as shown in Photo 5.

Put the piece back on the form and glue the final two laminations to it. When the glue is dry, joint one side and cut the other on the table saw to clean up the rough edges. Then cut the piece to its final width of  $1\frac{3}{8}$ ". Remove material from both sides if necessary to keep the groove centered. Don't worry if the piece is narrower than specified, just adapt the width of the notches in the base and disk to fit.

Cut a piece of wood for the base into a circular shape slightly larger in diameter than is specified in the Materials List. If necessary, face glue two or more thinner pieces to make up the necessary thickness.



Mount the base on a head stock and turn it to the shape shown in the Side View. You may want to use the tailstock to help support the piece while you turn it roughly to size as shown in Photo 6. Sand the base while it is still on the lathe and apply a coat or two of finish. (I used Minwax Antique Oil Finish.)

Set a tee-bevel to 84° and mark one end of the bend as shown in Photo 7. Cut along your layout line on the band saw. Measure 25" from the cut end and make a mark along the outside of the curve. Cut the curve to length at this point. This cut should be more or less square (or as square as you can make something along a curved line.)

Lay out a radius line on the bottom of the base as shown in Photo 8. Lay-out two additional lines parallel to the radius line and 1<sup>1</sup>/<sub>16</sub>" on either side of it. When working with dark woods such

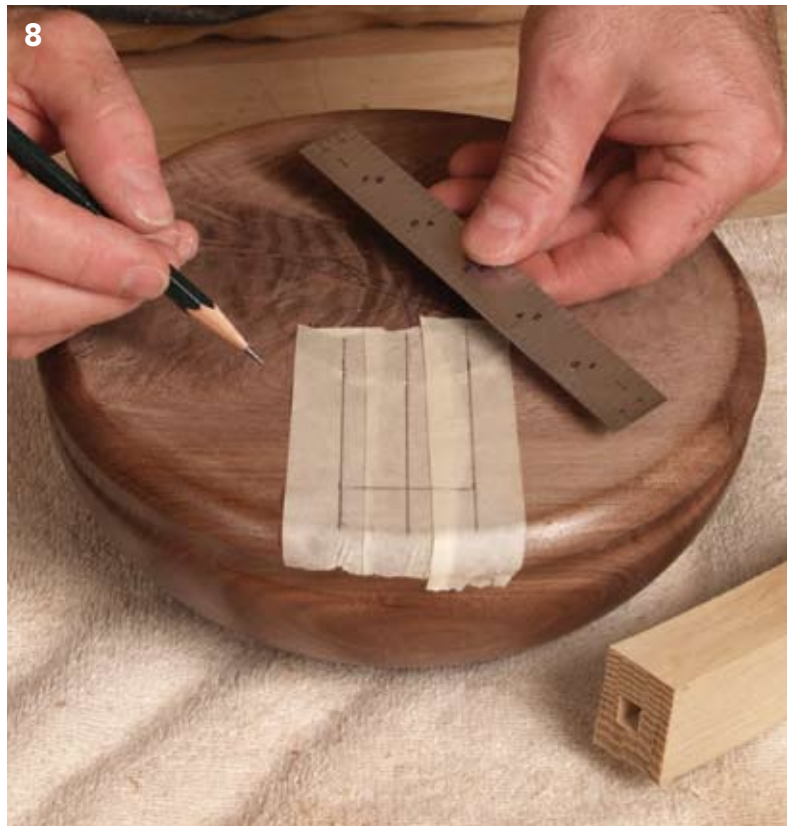

SIX The exact shape of the base isn't critical, although it should be relatively heavy to help keep the lamp upright. Here I have the tailstock in position to provide a little added support as I rough the piece to its general shape.

SEVEN To lay out the initial cut on the curve, set a tee-bevel for 84 degrees and hold it along the inside of the curve. While the angle you mark may be somewhat different from that I marked, it will be close enough.

EIGHT Draw a radius line from the center of the base out to the rim. Then add two lines parallel to the first. Each of these lines should be parallel to the radius line and 1<sup>1</sup>/<sub>16</sub>" on either side. Double check to make sure the lines are 1<sup>3</sup>/<sub>8</sub>" apart.

as walnut, I often will attach a layer of masking tape on which to make my layout marks.

Lay out a perpendicular line between the lines you drew that were parallel to the radius line. This line should be in from the edge of the base a distance equal to the thickness of the bent piece. Saw along the parallel lines as shown in Photo 9.

Remove the waste between the cuts with a chisel as shown in Photo 10. Try the bent piece in the notch and adjust the notch's angle until the bottom of the bent piece (the end you cut at an 84° angle) seems to be parallel to the bottom of the base.

Cut a piece of stock for the top disk to the size listed in the Materials List. Cut it round on the band saw and cut a notch in it for the bent piece. Like the notch in the base, the bottom of the notch in the base is angled. Again, the exact angle may vary, but it will be about 120°. The important thing is that the disk ends up parallel to the ground. The approximate size of the notch is shown in the Disk Detail.

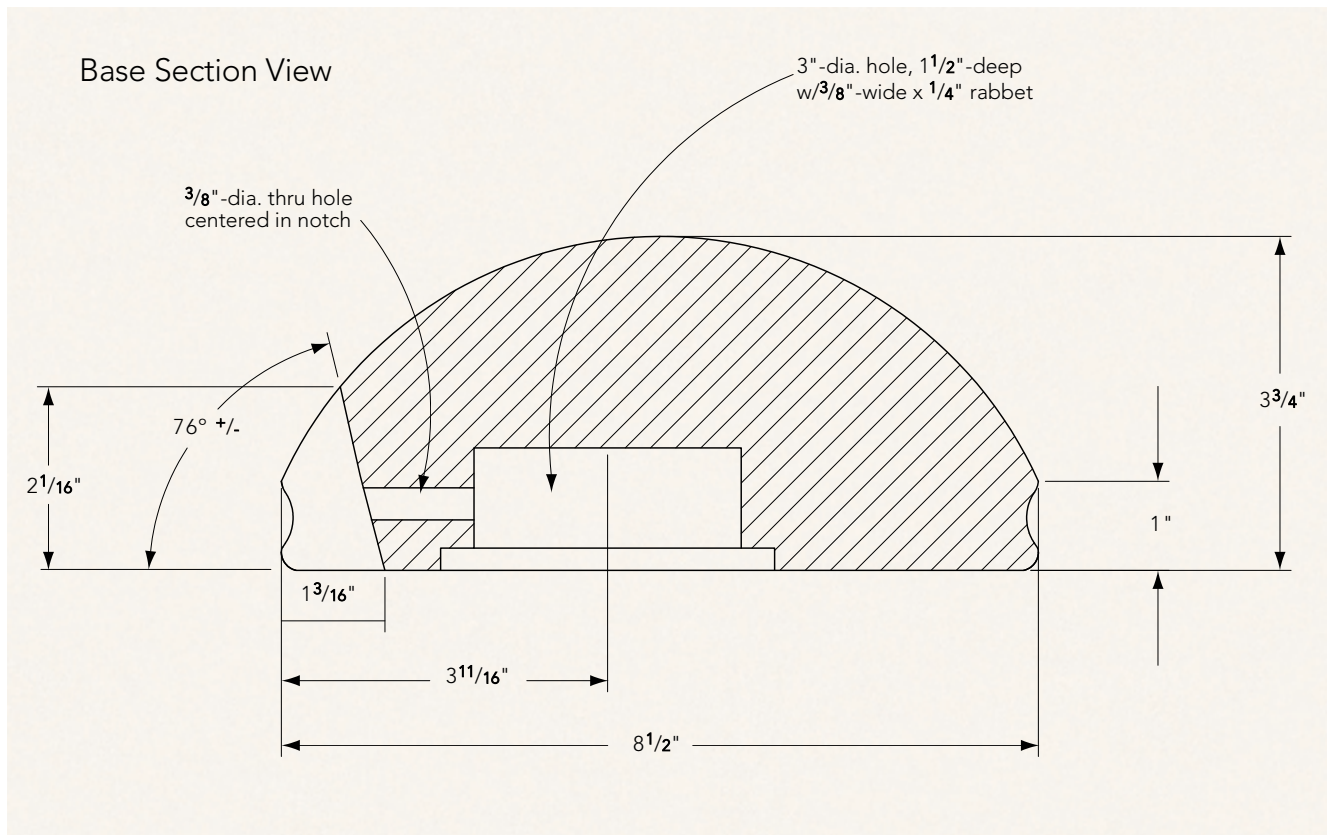





Once you have the disk fit to the bent piece, trace its location on the bent piece's sides and across its front. Use these lines as guides as you cut a 1/8" deep notch in the bent piece to help keep the disk in place as shown in Photo 11.

Drill a 1 3/32" hole through the center of the disk. Counterbore this hole with a 1" diameter Forstner bit, leaving the disk about 1/8" thick at the bottom of the counter bore. Drill a 1/2" hole that starts in the notch and intersects with the counterbore as shown in Photo 12.



TEN With so many curves to deal with, you have to work a little more intuitively, fitting pieces together so they look right rather than relying on hard measurements. The important thing about attaching the bent piece to the base is getting the bent piece to be perpendicular to the table top when viewed from the front.

ELEVEN When you make the cuts for the notch in the bent piece, note that they should be angled to match the lines you traced from the disk.

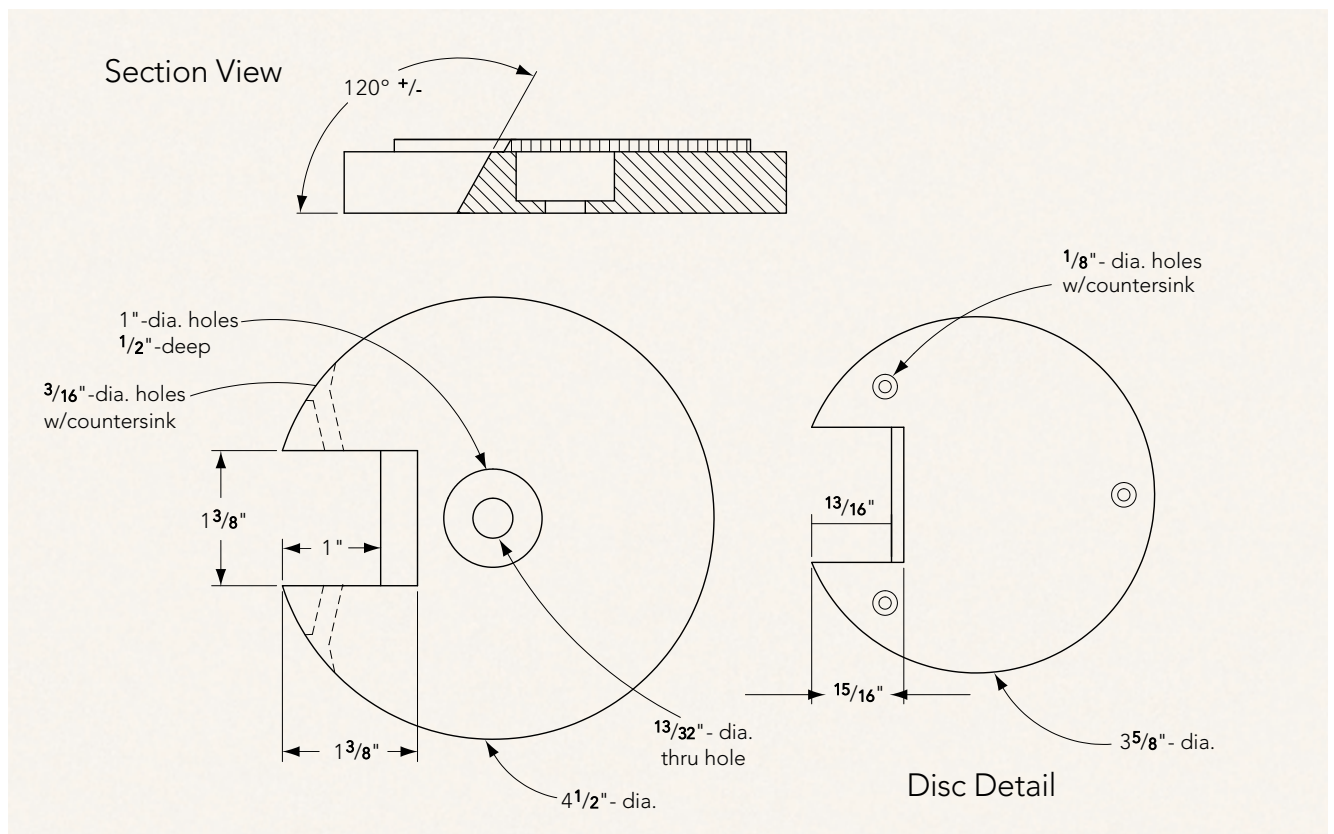

Drill a matching hole in the bent piece so the wires can get into the groove you routed earlier.

Ease the edges of the cap with a  $\frac{1}{8}$ " roundover bit chucked in a table-mounted router.

Cut a piece of  $\frac{1}{8}$ "-thick material for the cap. Cut it round on the band saw and notch it to fit around the bent piece. Drill and countersink three holes for the short screws that will hold it in place atop the disk.

Drill a  $2\frac{1}{4}$ "-diameter  $\times$   $1\frac{1}{2}$ "-deep hole in the bottom of the base. Locate the hole as shown in the Base Section View. Chuck a  $\frac{3}{8}$ " rabbeting bit in your table-mounted router and cut a  $\frac{1}{4}$ "-deep rabbet around the edge of the hole.

Drill a  $\frac{1}{2}$ "-diameter hole in the concave face of the bent piece so you can get the wires out of the groove. Center it from side-to-side and locate it 1" up from the lower end of the piece. Drill a corresponding hole in the center of the notch in the base leading into the  $2\frac{1}{4}$ " hole you drilled earlier.

Cut a piece of  $\frac{1}{4}$ " material into a 3" diameter circle to serve as a cover for the wiring. Fit it carefully into the rabbet, then drill both pieces for the screws that will hold it in place as shown in Photo 13. Drill a  $\frac{1}{4}$ " hole through the center of the plate for the power cord.

**TWELVE** As you drill the hole in the disk for the wires to pass through, grip the disk with a wooden hand screw. The clamp makes the piece easier to hold onto, and it helps ensure the hole is properly aligned.

**THIRTEEN** I found a piece of Styrofoam packing material that makes a great holder for the base when I have to work on its underside. Try to be a little smarter than I was and offset the screw from the hole you drilled for the wires to come through.

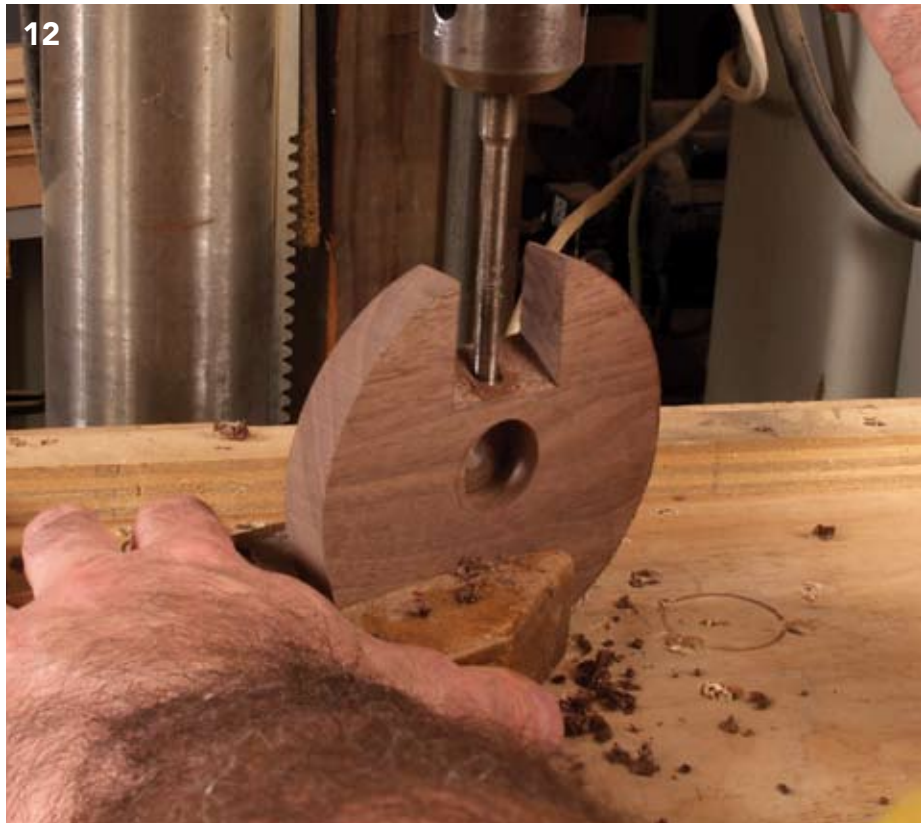

Drill two  $\frac{3}{16}$ " holes through the bent piece for the two screws that attach it to the base. Locate these screw holes on either side of the  $\frac{1}{2}$ " hole you drilled for the wires and counterbore them for plugs with a  $\frac{1}{4}$ " bit.

Cut a plug to fill the hole where the groove comes out the top of the bent piece. Glue it in place and sand it flush, gently rounding the end of the bent piece in the process.

Temporarily assemble the pieces, screwing the bent piece to the base and the disk to the bent piece as shown in Photo 14.

Disassemble the lamp and finish all the pieces. I finished the lamp in the photo with several coats of Minwax Antique Oil Finish, a wiping varnish.



**FOURTEEN** Prior to finishing, put all the pieces together to make sure everything fits as it should. Double check that the bent piece is perpendicular to the table when viewed from the front.

## ASSEMBLY

1. The pendent kit comes with a wire that runs from the socket up through a dish-like metal fitting that is meant to go against the ceiling. You won't be needing this fitting, but you will need some of the hardware that is attached to it. Loosen the set screw that holds the wire in the collar in the center of the fitting and pull the wire free. Also undo the nut that holds the collar to the fitting. Hang on to the collar, the hex nut, the washer, and the nipple that everything is threaded onto.
2. Push the nipple up through the hole in the center of the disk until the collar butts up against the disks underside. Fasten it in place with the washer and the hex nut. Feed the wire from the fixture up through the collar until the fixture is hanging about 4" below the disk. Tighten the set screw to lock the wire in place.
3. Strip the heavy plastic tubing off so you are left with the three individual wires. Be careful not to cut the insulation on the wires. Exam the wires carefully. You'll find one has a green stripe, one has a white stripe and one has no stripe on its insulation. Clip the wire with the green stripe off near where it comes out of the nipple. This is a ground wire and won't be necessary for a table lamp.
4. Push the two remaining wires through the hole that leads to the notch. Then feed them into the bent piece and push them down until you can fish them out the hole in at the bottom. From here, push the wires through the hole that leads from the notch into the  $2\frac{1}{4}$ " hole.
5. Work the slack out of the wire and screw the disk to the bent piece and the bent piece to the base.
6. Cut the excess wire, leaving your self about 8" of wire to make the connections. Push the end of the lamp cord up through the hole in the cover plate and tie it in a knot so it can't pull back through.
7. Strip about  $\frac{3}{4}$ " of insulation off the ends of the individual wires. Twist the lead with the white stripe together with the ribbed lead on the lamp cord. Twist the other two leads together as well. Cap the connections with wire nuts. Coil the Wires into the  $2\frac{1}{4}$ " hole and screw the cover plate in place.
8. Attach three feet to the underside of the base. Plug the holes in the bottom of the bent piece and sand the plugs flush. Wipe some finish over the plugs to blend them in with the rest of the piece. For more details of making the electrical connections, see page 8. As always, if you are not sure how to do the wiring, consult with a professional.