

American Trestle Table

One of the oldest designs for a dining table is also one of the most highly engineered and contemporary. But will its unusual dimensions work in a modern home?

Traditional trestle tables have a bit of an austere reputation. They show up in Gothic churches, prim pilgrim homes and in severe, stripped-down Shaker meeting halls. They are a form of furniture that has been boiled down to its bare bones – take any one part away, and a trestle table will surely collapse.

Once you build one, you will also realize that they are an engineering marvel and a clear precursor to the invention that built our skyscraper cities: the I-beam. Still, despite their spare charm and long history, there are some things about the dimensions of trestle tables that don't conform to our typical expectations for tables.

For starters, they are shockingly narrow. Most furniture-design books insist that the top of any dining table should be 36" to 42" wide – and 48" wide isn't out of the question. But when you look at the historical record, the widths of trestle tables are, quite literally, in your face. One of my favorite early 17th-century trestle tables in Millis, Mass., is a slim 25" wide. By comparison, Shaker trestle tables seem positively luxurious with 27" and 31¼" widths.

And the trestle form frequently looks quite fragile, which seems at odds with the fact that these tables are typically the centerpiece of a casual dining area. They show up in taverns, meeting halls and other communal dining rooms, and the surviving examples exhibit the marks and scars of heavy use.

For many years, I've wanted to build a trestle table to replace the store-bought, white-pine apron table my wife and I got soon after college. The pine apron table was a testament to everything I disliked about commercial furniture: The top was pieced together using narrow, knotty and poorly matched boards. (A monkey could have done a better job of planning the tabletop.) The legs had bulbous turnings that were sloppily sanded. And the hardware that joined the legs to the aprons had to be snugged up regularly.

But if I hated our dining table, then I was equally afraid of the trestle table I wanted to build, which looked narrow, tippy and ready to



PHOTO BY AL PARRISH

Trestle tables are comfortable in any style home, from early American to Bauhaus. And like the timeless styling, the engineering is a remarkable combination of old world and new. The wedged through-tenons are as old as ancient Egyptian furniture, and the resulting form is much like a modern I-beam.

collapse, so I put it off for 15 years. But during a recent day trip to the Shaker Village at Pleasant Hill, Ky., I sat at the tables there. They were indeed narrow, but that made them more intimate for conversation. They were lightweight, which allowed them to be moved with ease. And after 150 years of use, they were still rock-solid.

I left Pleasant Hill that evening during a spectacular thunderstorm, but the fireworks over Harrodsburg, Ky., didn't catch my eye. I was too wrapped up in working out the details of my table in my head.

An Economy of Materials

After a few hours of CAD work on my laptop, I had another small revelation: These tables require remarkably little material. For the prototype, I had planned on using Southern yellow pine for the base. For the tabletop, I had set aside two fitch-cut cherry boards from a local farm that were each about 18" wide, if you measured the bark. I had purchased these cherry boards green for about \$90 and had been drying them in my shop – I thought they were quite the bargain. But when I made my shopping list for the base, I was pleased



To speed the acclimation of your lumber to its environment, cut it to close width and length. Stack the pieces to allow airflow through the wood, and check its progress with a moisture meter.

to discover that the base required only three 10'-long 2 x 12s – about \$37 of yellow pine.

There is a definite downside to using yellow pine – it can be wet. And a check with a moisture meter pointed out the problems in this pine. Fully acclimated yellow pine usually reads about 9 percent moisture content (MC) in our shop. This stuff ranged from 12 percent to 16 percent MC.

So I began by marking out all my parts and ripping and crosscutting them to rough size – about 1" longer and 1/2" wider than their finished dimensions. If your wood is fairly straight, this is a safe operation for the table saw. If your wood is quite twisted, plan B should be a band saw or handsaw. Cutting up the 2 x 12s wet does two things: First, it speeds their drying by exposing end grain – most of the moisture enters and leaves wood through the end grain. Second, it helps squeeze the maximum thickness out of the parts – bows, cups and crooks are minimized by cutting a larger board into smaller pieces.

After a week of waiting, the boards were all within a couple points of equilibrium and construction could begin. The first step was to mill all the yellow pine to 1/4" thick using a jointer and planer. The joinery in surviving trestle tables is remarkably robust: usually wedged or pegged through-tenons. And so I followed suit.

Each end of a trestle table has a foot, leg and brace. And these end assemblies are joined by a long stretcher. In this table, the leg and foot are joined by a wedged and pegged through-tenon. The brace and leg are joined by a bridle joint. And the two end assemblies attach to the stretcher with a big pegged and wedged through-tenon.

The feet, legs and braces are each made up of two pieces of pine that have been face-glued



Begin your joinery by marking out the location of the mortises in the feet. Clamp all four boards together and mark the joinery simultaneously to reduce measuring errors.



Before face-gluing boards together, I dress the mating surfaces with a jointer plane. A few swipes remove imperfections left from the planer. At the end of each stroke, you want to reduce pressure on the toe of the plane to make the surface truly flat. Here I'm removing my right hand from the tool during the stroke to illustrate the point.



To keep your hands as far away from the dado stack as possible, use a fence with a stop on your miter gauge to set your cut. Your setup does not have to be fancy: The fence can be a piece of plywood screwed to your miter gauge. The stop can be a scrap of wood clamped to the fence.

together to create 2 1/2"-thick pieces. To ease construction, I milled the mortises in the feet and legs before face-gluing these components together. This technique allows you to mill the mortises with a saw (such as a table saw, band saw or handsaw) instead of a boring machine, and it results in more accurate joinery.

Mortises With a Saw

The mortise in each foot measures 1 1/4" thick, 2" wide and 3" deep. So each foot piece requires a notch that is 3/8" x 2" x 3". The mortise in each

leg is 3/4" x 3" x 2 1/2", so each leg piece requires a notch that is 3/8" x 3" x 2 1/2". With the joinery marked, cut your notches. I used a dado stack in my table saw, which is only one of the many options available. I've also done this step with a band saw or a handsaw plus a coping saw. Let your tools be your guide.

To assemble the legs, feet and braces, apply an even coat of glue to one part and place its mate in position. If your joint is good, it should take only three or four clamps to snug everything up. The glue will allow your parts to slip around as

1 SQUARE = 1"

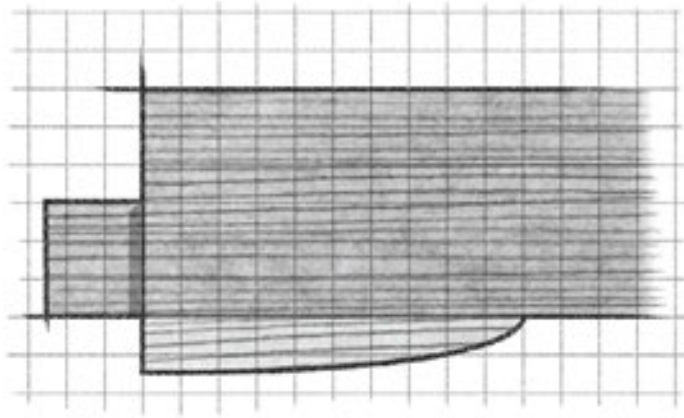

LEG JOINT DETAIL

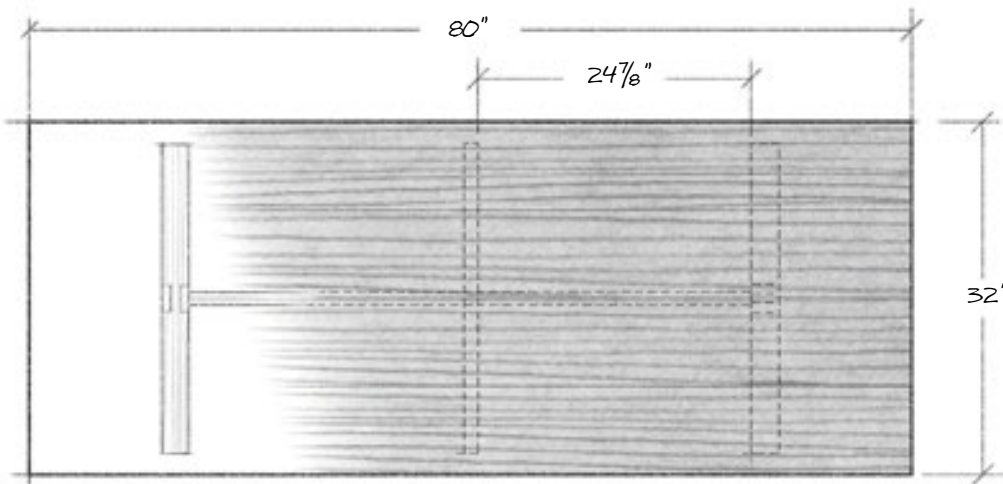

TOP VIEW

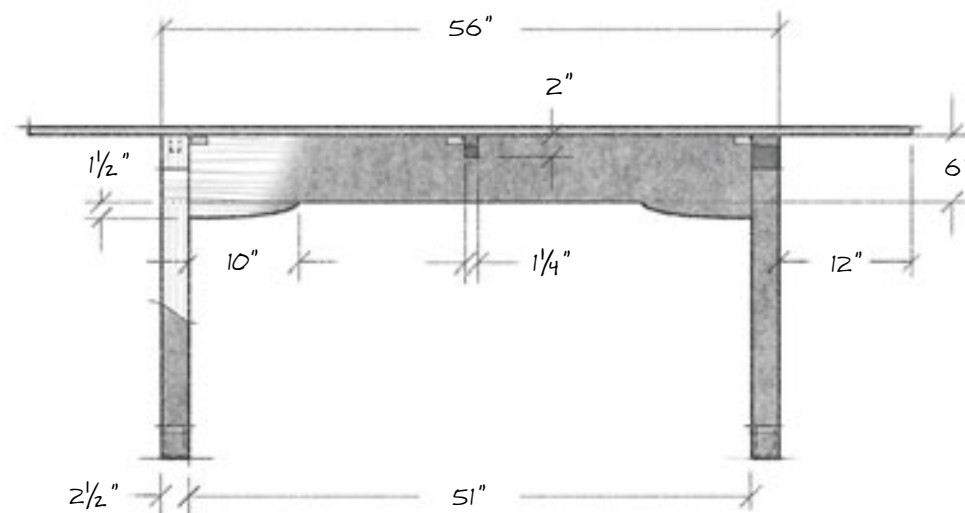

FRONT VIEW

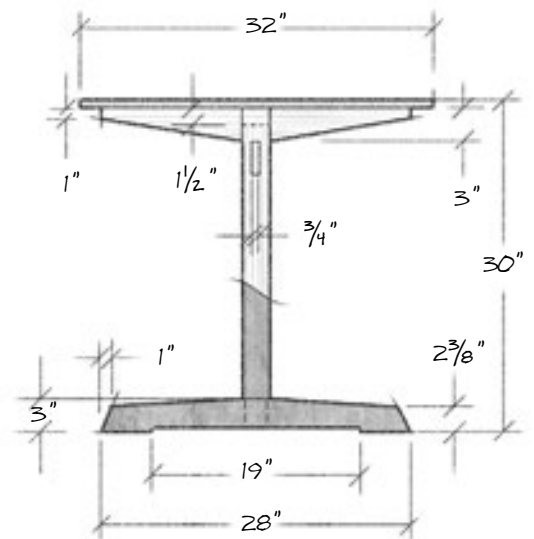

SIDE VIEW

AMERICAN TRESTLE TABLE

you apply pressure. Do your best to keep the notches lined up for the mortises, though small misalignments (as much as $\frac{1}{16}$ ") can be remedied by wedging during assembly (wedging atones for a variety of sins).

Allow the glue to dry. If you use yellow pine, keep the assemblies in the clamps for five hours. (This was the advice of the technical specialist at Franklin International, which makes Titebond.) Yellow pine's resin can resist the glue's absorption. Once the assemblies are liberated from their clamps, you need to square them up and even out any misalignments in the parts. A jointer plane can do this, as can light passes with your powered jointer and planer. (I like to use the jointer plane because it leaves a nicer surface; but then, I really like using jointer planes.)

Now you can cut the tenon on the end of each leg that will join it to the foot. This is a big tenon — $1\frac{1}{4}$ " x 2" x 3". You can cut this using the same tool you used to make the notches: a dado stack in your table saw, a band saw or a handsaw. In the end, you want it to fit snugly where the tenon's face cheeks meet the mortise walls. The tenon's edge cheeks can be gappy. Wedges will tighten everything up; so focus on the face cheeks.

A Puzzle Joint at the Top

The point at which the leg joins the brace is a bit of work. There's a lot going on at this three-way intersection. Not only do you have the leg and brace coming together, but you also have to get the stretcher in there and keep all the joints balanced and strong. You could cheat and lower the location of the table's stretcher near the floor. But this will weaken the overall strength of the table.

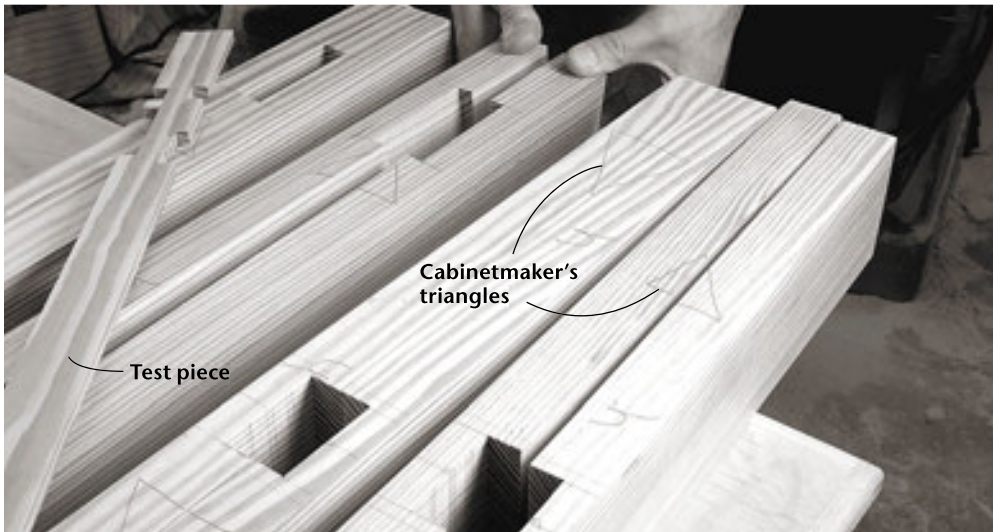

After the joinery is cut, match up the pairs again. Note the cabinetmaker's triangles I've scribed on each piece. These triangles, which I mark on every assembly, help keep like parts together and pointing in the right direction. They remain on the work until the very end.



With the dado stack still in the saw from cutting the notches, it was the logical choice to form the tenon. The same rules apply: Use a fence and a stop to achieve accurate results safely.



To fit the tenons to the mortises in the feet, use a rabet plane, shoulder plane, rasp or chisel. I used a rabbeting block plane, which is ideal for long tenons such as these.

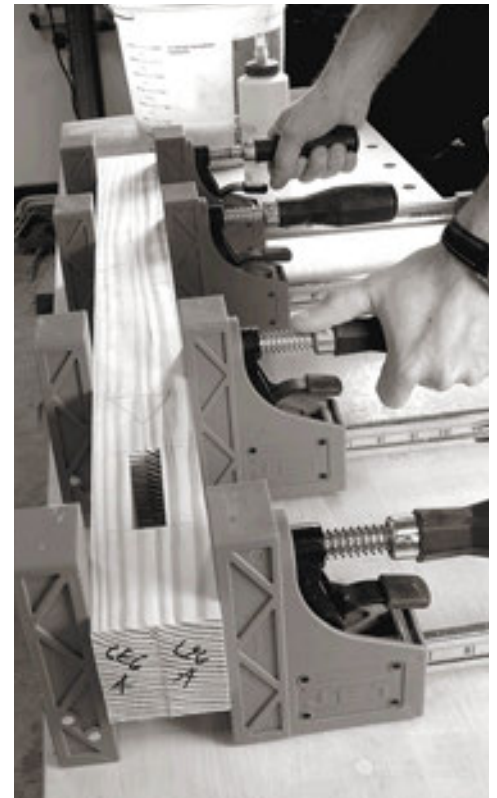

Four clamps were more than enough to glue each leg. During these glue-ups, I wipe off the oozing glue with a damp rag so I can see what the joint line looks like. Just because you have squeeze-out does not mean your joint is closed tight.

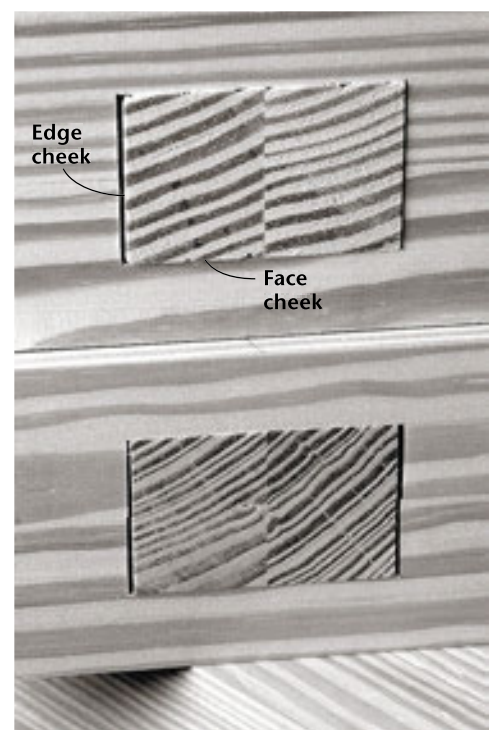

In the end, this is what your joints should look like: The face cheeks of the tenons are tight against the mortise walls; the edge cheeks have a little slop for wedging.

American Trestle Table

NO.	PART	SIZES (INCHES)			MATERIAL	NOTES
		T	W	L		
□ 1	Top	3/4	32	80	Cherry	
□ 2	Feet	2 1/2	3	28	Pine	
□ 2	End braces	2 1/2	3	28	Pine	
□ 1	Mid-brace	1 1/4	2	28	Pine	
□ 2	Legs	2 1/2	2 1/2	29 1/4*	Pine	1 1/4" x 2" x 3" tenon, one end
□ 1	Stretcher	1 1/4	6	56 1/4*	Pine	3/4" x 3" x 2 5/8" tenon, both ends
□ 2	Corbels	1 1/4	1 1/2	10	Pine	

* includes extra length for trimming



The band saw makes simple work of the notch in the top of the leg. Define the straight walls of the joint, then cut diagonally to remove the waste between. Nibble the waste at the bottom of the joint up to your layout line.

Placing the stretcher flush against the tabletop supports your top and tightens up the entire table by giving you that I-beam construction.

So in the end, it's worth the extra fuss.

To join the brace and leg, I chose a bridle joint secured with a peg. The female part of this joint is a 1" x 2½" x 1½" notch that's centered in the top of the leg. The male part of the bridle joint consists of two complementary notches on the sides of the brace and one big notch on the bottom of the brace.

Begin cutting the joint by making the notch in the top of the leg. The band saw is the logical machine for this operation; stay away from the dado stack for this one – you would have to stand the leg on end during the cut, which is quite a dangerous thing to do.

The notches on the brace can be cut on either the band saw, table saw or by hand. I've done it all three ways in building the prototype and finished example of this table. The table saw is more accurate, though you have to raise the dado stack up pretty high to make that notch on the bottom of the brace. The band saw and handsaw options are much safer, though they require more hand skill to execute. In the end, I recommend the band saw or handsaw.

When you dry-fit all these joints together, don't be dismayed if the assembly seems twisted. There is a lot of joinery surfaces coming together in this assembly. Here's how I deal with the problem: a jointer plane. (Do you sense a pattern?) Dry fit all the parts and then level the joints and remove twist in the assembly by working across the joints with your jointer plane.

With your joints flush and your assemblies flat, take everything apart and add the details of this table that will transform the ends from a simple "H" into something interesting to look at. The first order of business is to cut tapers on the feet and brace. First crosscut the ends of the feet and



Measuring might mess you up here. Instead, lay out this joint by first striking centerlines on the leg and the brace. Line up the parts using a try square and mark the location of the joint on the brace. When the joint is complete, the leg and brace will nest together, with the tough end grain on the brace against the edge grain of the leg (to resist racking). Plus there's a fair amount of face grain in the joint to help gluing.



Note how I'm steering the cut from the far end of the leg. This actually improves control and makes your cut smoother. Guiding the work up by the blade results in a choppy cut.



The long sole of the jointer plane allows it to true both individual boards and assemblies, such as a door or the ends of this table. Don't be afraid to work across the grain with this tool; a power sander or smoothing plane will clean up the work later.



This looks like hot-dogging, but it's not. The work is under control at all times and it's easy to keep your digits away from the knives. It's far safer than some tapering jigs I've seen on the table saw.



The Veritas Chamfer Guide on my Veritas block plane is one of my handiest tools. In fact, I rarely take the guide off the plane. It cuts nice and even chamfers up to $\frac{1}{2}$ " x $\frac{1}{2}$ ". When you reach the desired chamfer, the plane simply stops cutting to let you know you're done. Brilliant.



The chamfers on the brace are short and simple. Lay them out, then work from both ends to the middle, which will eliminate blowing out your grain. Takes but a minute.

braces at 23° using a miter saw. Now lay out the tapers using the construction drawing as a guide. You could rig up a tapering jig to make these cuts using your table saw, but it is far simpler to use a band saw and then clean up the cut on your power jointer (or use a jointer plane).

This also is the time to cut the relief on the bottom of each foot. This is easily accomplished on the band saw. The $\frac{3}{8}$ " x 19" relief cut creates two pad feet on each foot. After making your cut on the band saw, a little work with a chisel and block plane tidies things up.

Once your tapers are complete, the remaining details are optional. On the prototype trestle table (which is now in my dining room), I moved straight to assembly from here. With the version shown here, I decided to add a few chamfers to dress up the design and add shadow lines, which will appear more graphic with a coat of paint.

The chamfers on the legs are $\frac{3}{16}$ " x $\frac{3}{16}$ ". You can lay them out and cut them in any way you please: router table, table saw or (my favorite) the chamfer plane. I also cut matching chamfers on the brace where the leg and brace meet.

Kerfs and Wedges Work Together

Wedging a mortise-and-tenon joint locks it permanently together (if that's your desire). For this table, I decided to cut two kerfs in the tenon and wedge each one. The kerfs are located $\frac{1}{4}$ " in from the edge cheeks of the tenon and run about three-quarters of the way down to the tenon's shoulders. Choose a saw based on how much of a gap you need to wedge. A full-size handsaw is best if you have a tight fit. A dovetail saw is best if your fit is sloppy.

Now you need to make some wedges. Look for stock that can take a beating without splitting. Ebony would be a terrible choice. Try white oak or hickory or even ash. We had some jatoba in our offcut pile that was the perfect thickness for this job. I took some small blocks of the stuff and beat it with a hammer to see if it split easily. It resisted my hammer, so I used it for the wedges.

I make my wedges with an 8° taper. It's a simple thing to do with a little sled I built that has the fence cocked 4° (see the story on wedges in this issue for more details). This method is fast, so make lots of extra wedges: some with fine points, others with blunt ones.

A wedged joint is far more effective if the mortise has a slight trumpet shape. The wedges will spread the tenon at the wider opening, locking the joint permanently. I create this trumpet shape by simply chiseling away a little (say $\frac{1}{16}$ " to $\frac{1}{8}$ ") from the two ends of the mortise where the wedges exit. You don't need to be precise about it; just make the mortise wider where the wedges go.

Assemble the Ends

After all this work, assembly is fast and simple. I chose to drawbore both the bridle joint and the mortise-and-tenon joint. Drawboring is a pegging technique we covered in detail in the Autumn 2005 issue. If you don't wish to drawbore the joint, simple $\frac{3}{8}$ "-diameter pegs will do. However, if you are going to drawbore the joint, you should drawbore the tenon first and then wedge it – not the other way around.

To assemble, paint glue in the mortise and the notch in the top of the leg. Add your wedges and pegs to the joints. If you want some extra insurance, add a couple clamps across the foot and brace to snug things up. When the glue is dry, cut your pegs and wedges flush.

A Solid Stretcher

The long stretcher between the end assemblies is what will keep this table from racking along its length, so this joint needs to be carefully fit. The stretcher's length adds some extra challenge to the process. At almost 5' long, it's too lengthy to wrestle over the table saw (without special equipment). For the prototype table, I used a tenon saw, but because the joint and stretcher are both huge, securing the work and sawing to the line was a challenge. I tried a couple other techniques that combined hand and power tools, but in the



A few good taps on a chisel will open up the mortise's exit point. You also can use this opportunity to square up any misalignments when you glued up the two blanks to make the feet.



A Japanese flush-cutting saw is a marvel at cleaning up these wedged joints. Use light sawing pressure and work around all sides of the joint to keep the saw cutting true.

end, the best solution was to use a router with a straight bit, followed by a handsaw.

The trick is to define the shoulder of the joint accurately with the help of a fence clamped to your work. I wouldn't recommend trying this with a router that has a round base – a flat area on the base is more accurate. (If your router has a round base, temporarily replace the round plastic sub-base with a square piece of $\frac{1}{4}$ " plywood.)

Set the bit's depth to $\frac{1}{4}$ " and cut the shoulder. Now waste away the 3 " x $2\frac{3}{8}$ " area that will become the tenon. Don't waste away the area that will be later removed with a handsaw at the top of the stretcher – you need this material to support the base of the router.

Repeat this operation on the opposite face of the stretcher, and then on the other end. Remove the bulk of the remaining waste with a handsaw. I actually found this easiest to do with the stretcher laid on low sawhorses and one knee holding it in place while I sawed. Then clean up the shoulder



A piece of fall-off is ideal material for the fence for this cut. I marked out the joint with a knife all around the stretcher and then positioned the fence carefully to cut right up to the knife line.



With the routing complete on this face cheek, this is what you should have. The unrouted area will be cut away with a handsaw in the next step.



Note that there is no shoulder on the bottom of the stretcher's tenon. The bottom shoulder will be created by gluing on the corbels in the next step. As you clean up the top part of the shoulder, use a square to ensure you are removing all the bumps that could interfere with a solid fit.

with a block plane and chisel and begin to fit the tenon in its mortise.

Now shape the corbel and glue it to the bottom edge of the stretcher. If you are not going to paint your base, be sure to carefully match the grain so the corbel and stretcher look like they are one piece.

One More Brace – and Buttons

A table this size requires one more brace in the stretcher to support the top. For the prototype table (which had an 8'-long top), two mid-braces were necessary. The smaller braces are simple to cut and fit. I attached the mid-brace using a bridle

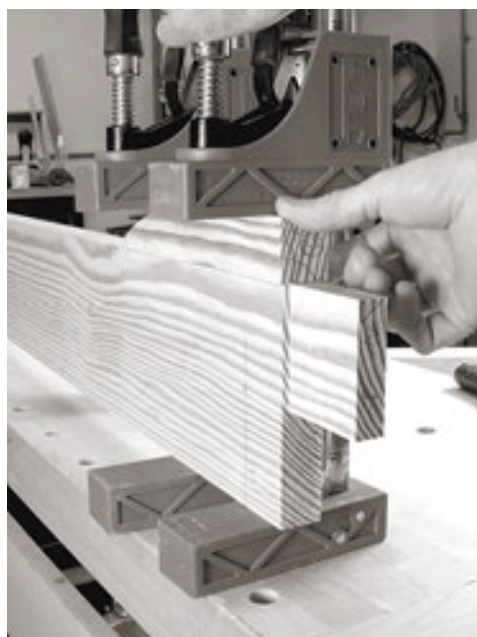

Adding the corbels to the stretcher greatly simplifies cutting the detail and fitting the tenon. I got this idea from a Shaker example.

joint. First saw a 1" x 1/4" notch in the stretcher and the mid-brace. Fit them using a chisel. Secure the mid-brace with glue and a dowel.

Now you can assemble the entire base using the same routine you used to join the feet to the legs. Saw two kerfs in the tenons on the stretcher. Make wedges. Peg and wedge the joint.

With the base assembled, there are likely going to be some parts that aren't perfectly aligned. You want the top surfaces of the base to be in the same plane, though that's a challenge to achieve during glue-up. The top edge of my stretcher was a bit proud, so I knocked it down using a jointer plane.

The tabletop is secured to its base using wooden buttons. Each button has a 1/4"-thick x 1"-long tongue that fits into a matching notch in the base. Then the buttons are screwed to the underside of the top. Making the buttons is easy: I took some wide 3/4"-thick scrap and milled a rabbet on the end. Then I ripped the buttons free from the scrap board.

To make the notches in the base, I used a biscuit joiner. The blade of a biscuit joiner is 1/8" thick, so two overlapping cuts gave me the 1/4" groove I needed. If you don't have a biscuit joiner, you can secure the top with screws. Drill clearance holes through the braces and ream them out to allow the top to expand and contract.

The base is now complete and you can turn your attention to the top. For the project shown on the cover, I asked Senior Editor Robert Lang to make the top because he was writing the story on splines in this issue. For details, see his story titled "A Proper Top for the American Trestle Table" at right.

For the prototype, I made the top using the air-dried cherry boards I mentioned at the beginning of the article. They had to be dressed by hand because they were too wide for the machinery.



Again, this isn't a show surface, so you don't need to worry about planing across the grain; just get everything flush and in the same plane. I secured my table base against my sawbench for this operation.

The challenge of such a top is an article unto itself. Robert's approach to the top is simpler, looks great and is easily executed.

Notes on Finishing (and Feasting)

The base is painted a traditional Shaker green. It might look brighter than what you expect from Shaker furniture, but it's likely dead-on. John T. Kirk, the author of "Shaker World" (Harry N. Abrams), created this green by mixing it according to the Shaker's recipes. The other hues, particularly the red and yellow, were also bright to our eyes. We usually expect muted tones from the Shakers, but those somber colors are probably the result of fading and patina from age.

To get this color, we let our local Sherwin-Williams do the matching work. They came up with a color they call "Shade-Grown" (SW 6188). For details on applying a painted finish, see "How to Paint Furniture Like a Professional" on page 30.

With the table complete, it's a remarkable bit of engineering. I cringe (and then marvel) at how my 5-year-old gymnast can vault herself off its edge while the whole thing stays rooted. It is so lightweight that I can lift the end of the 8'-long prototype with two fingers to vacuum up bits of macaroni and cheese.

And then there's the width. The table here is 32". I made the first version at 28". I like the narrow width; eating and entertaining is a far more intimate affair because of it. There's plenty of room for the place settings, but the narrow width brings an unexpected, welcome closeness.

This is a good thing for both of my families. The table at home knits us tighter together at dinnertime. The version shown here, which now graces our magazine's office, keeps the editors close at hand as we plan the next issue. **WM**

— Christopher Schwarz

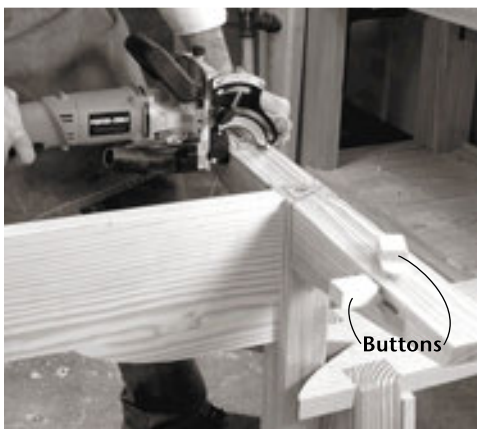

Set the biscuit joiner's fence so that there's $\frac{1}{2}$ " between the fence and blade. Make all the cuts in the table base on your braces and mid-brace. Then set the fence so there's $\frac{5}{8}$ " between the fence and blade and repeat all your cuts.

A Proper Top for the American Trestle Table

One of the things that never fails to impress me about old furniture is the beautiful wide planks that were available. One hundred fifty years ago, a tabletop of this size could have been made from one or two wide planks. The disappearance of old-growth wood has forced us to make tops from narrower pieces, and along the way we've adopted methods based on theories that sound good, but don't always make sense when examined closely.

Old woodworking textbooks barely touch on gluing two boards together edge to edge to make a panel or tabletop. If you had wide enough boards available, why would you want to? None of the methods commonly suggested today, such as ripping wide boards into narrow strips or alternating the direction of growth rings in every other board, are ever discussed. However, these methods appear so often today (passed on by many shop class teachers) that many woodworkers have adopted them as rules. The trouble with them is that if you are working with properly dried wood at equilibrium with its environment you are only making more work for yourself in order to make a top that is less stable and far less attractive than one made from as few pieces as possible.

The most attractive top is a single, wide board. The next best thing is one made from a few wide pieces with the grain and color matched so that it is as close as possible in appearance to the ideal. Any method that puts the appearance of the finished top last is artless. Get your hands on the widest stock you can, let it equalize to the environment of your shop, and get the edges straight and the faces flat. Match the grain on adjacent pieces so that the top looks good and don't worry about anything else.

I spent almost as much time selecting and arranging the boards for this top, as I did in milling, assembling and finishing them. To get the five boards in this finished top, I rooted through a stack of about 50, initially selecting about 20 of the widest, straightest pieces. I lined those up to compare the grain and color and rejected another eight boards before I began milling the remaining dozen. Four more boards either revealed some ugliness, twisted during jointing, or were too warped to mill flat.

My normal procedure is to edge glue boards together using only butt joints. My first attempts at this were more difficult and frustrating than what I am able to do today. Along the way, I've learned to prepare stock that is straight and flat, and acquired equipment to make that process relatively easy. I've learned what can go wrong, and ways to prevent or



Even though a single board wouldn't have a repeating pattern of cathedral arches and straight grain, careful attention to matching similar patterns on the edges of individual boards results in an attractive top.

repair that. If I were starting over, I might take a different approach, and incorporate an aid to align the parts like the splines discussed on page 12.

Matching the grain for an attractive top is more art than science, but it's vitally important, and there are some techniques to make the process easier. One of the secrets I've already divulged – pick through as much lumber as you possibly can to get the boards that belong in the top. Often you will find boards from the same tree, and these will give you the best opportunity of getting a good match.

I look for similar grain patterns, and most of the time flat- or plain-sawn stock will have a cathedral pattern in the middle of the board, with straighter grain along the edges. As I mill the boards and get them to finished width, I try to keep the arches centered, and match the straight grain to straight grain. If the straight grain isn't present on the edges, match one cathedral to another or try to get it to blend with the straight grain on the next board for the most attractive look.

Leaving the pieces long until after the top is glued together allows you to slide them back and forth until the best match is achieved. Some woodworkers will look at the grain direction on the edges while matching so that final smooth planing will be less likely to result in tear-out. I don't bother with this, although sometimes I wish I had. I don't want to be distracted from getting an attractive top, and I think one of the best challenges in woodworking is getting to really know the material and finding an effective way to deal with the tricky spots. Keeping the edges aligned during glue-up minimizes the amount of planing to be done afterwards and with a sharp plane iron there will be a magic angle at which to plane. The challenge is in discovering it.

— Robert Lang