



Building Shelves

Tips, Techniques and
Three Great Plans





magic

The magic of
engineering that is.
Where ultra-light
construction and a wall
attachment trick create
a seamless illusion.



shelves

Go ahead. Take a guess. Just what do you think one of these shelf units weighs? I'll give you a hint. The thickness is $1\frac{3}{8}$ ", the length of the longest part is 78" with the other leg 61". The height is 24" and the depth is 11". Some serious cherry timbers, you think? Say 40 or 50 pounds? Well, guess again friend 'cause you're off by a factor of two. Yes, 23 pounds for the big unit and just 20 pounds for the smaller one.

What you're looking at are three torsion boxes for each unit that use a solid cherry front edge, a top and bottom of $\frac{1}{4}$ " cherry plywood and several pine ribs that run cross grain to the cherry ply, or perpendicular to the front edge. It's all glued together to make a strong, flat and lightweight panel.

So how is it fixed to the wall? I'm not revealing that trick until the second act!

And by the way, if you think you've seen these shelves before, chances are you have. Our version was inspired by those shown in an Ace Hardware advertisement. I wasn't surprised to learn from Ace that they'd had hundreds of requests for plans to build this project. When I suggested we feature it here, they jumped at the chance.

Photo by Al Parrish

by Steve Shanesy

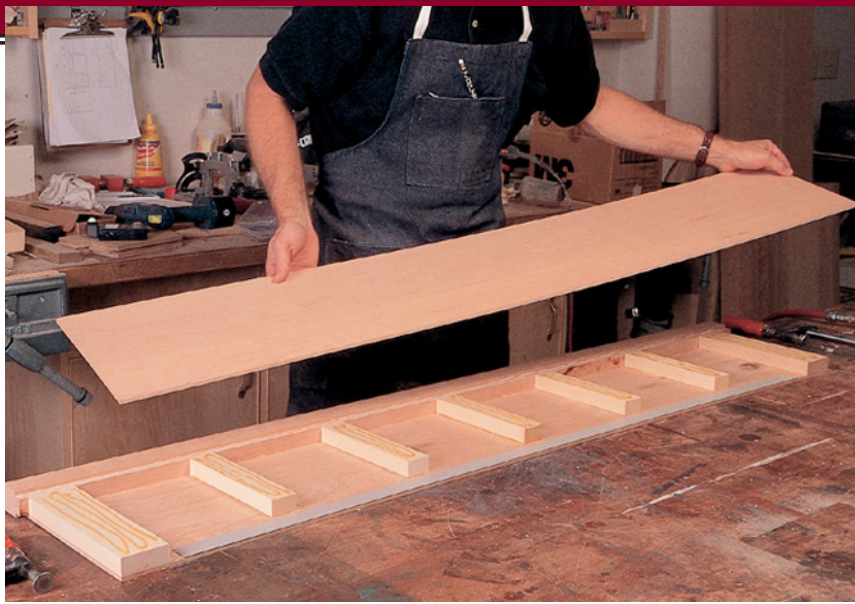

The shelf panel torsion box is made up of a solid cherry front edge, a top and bottom 1/4" cherry plywood skin, and a series of built-up ribs. All the parts are glued together to make a strong, light-weight, torsion-resistant panel (left).

After gluing and pinning the cherry plywood skin to one side, flip the partial assembly and glue all the parts. Then pin together both sides. If you don't have a pinner, you can clamp all the parts, although this method should be done in several stages (bottom left).

collecting your materials, begin by cutting the parts. Cut the plywood to length and width and mill the solid cherry for the front edges. At this stage, leave the solid cherry just a little long and keep the edges square, but do cut the 1/2" x 1/4" rabbet where the plywood will be joined to the solid front edge. You should make sure that the rabbet's depth leaves the solid edge flush or just proud of the plywood.

Build the Ribs

Now cut the pieces you'll need to provide the build-up between the two plywood faces. It should be exactly the thickness of the dimension created by the two rabbet cuts. Note there are, however, two different widths and lengths. The pieces that are assembled at each end are both longer and wider than the intermediate ones. Lastly, cut out four strips of plastic laminate to the dimensions given. If you don't have a plastic laminate such as Formica handy, you could substitute 1/16" x 1" pre-cut strips of aluminum or steel.

Torsion (or anti-Torsion) Boxes

Before heading to the shop, understand that what you are essentially making are a series of torsion boxes. Now why they are called "torsion" boxes and not "anti-torsion" boxes I'll never know (unless one of you would be kind enough to help me). To me, "torsion" means "twisted, or twisting," and what this construction technique does is prevent that from happening. Everything from aircraft wings and fuselages to hollow-core doors use this principle to keep their shape, even under a lot of stress. If you do much woodworking, you'll find torsion boxes a terrific solution to construction "problems" that come up from time to time.

After looking over the drawings and

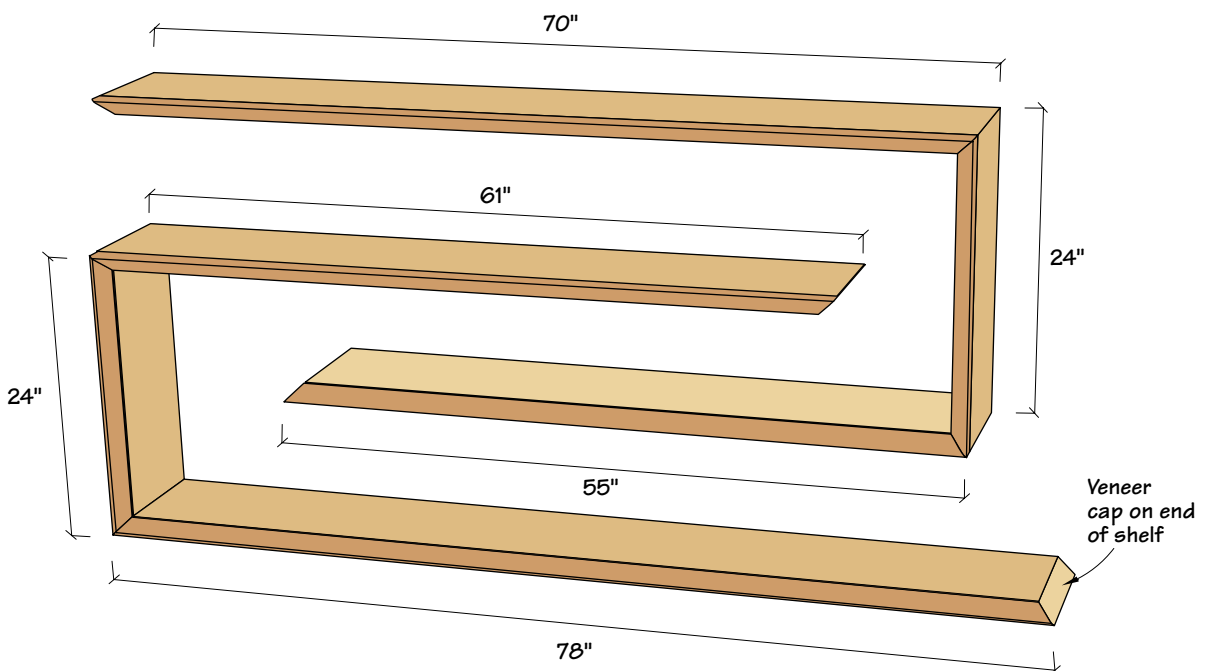

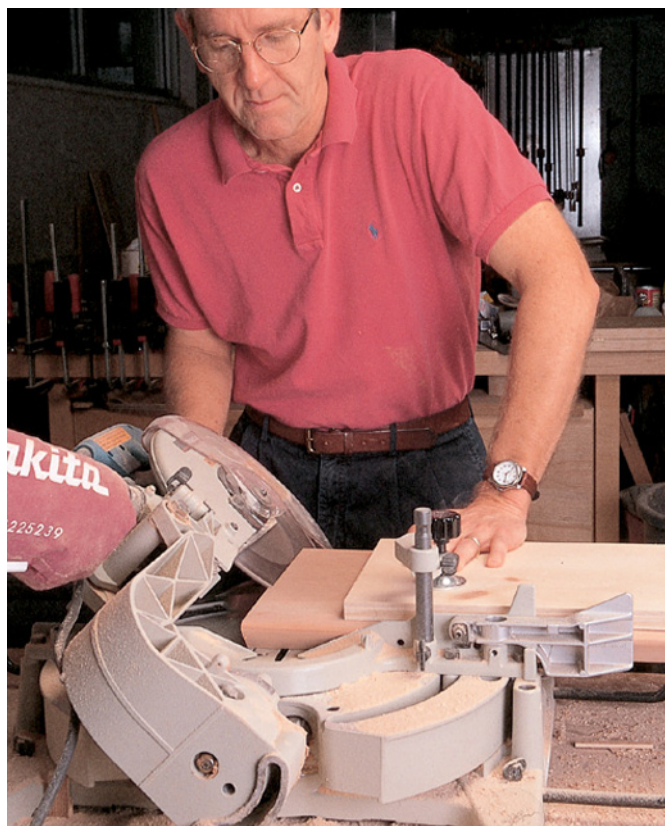

After the glue has cured and a 1/4" radius has been routed on the correct long edge of the front, cut the big chamfer detail on the table saw.

Each of the six panels must be mitered on both ends. Take special care to make sure your cuts are properly oriented to the panels' final assembly position.

Before starting assembly of the shelf panels, glue the plastic or metal strips to the inside back edge of the plywood that will be the top side of the four long shelves. This material will reinforce the plywood when you attach the shelves to the wall. If you use plastic laminate, use either white or yellow woodworking glue. If you use metal, use an epoxy or polyurethane glue.

Panel Assembly

Depending on how your shop is equipped, assembly could go relatively quickly, or it could take a while. It'll be quick if you

have a pneumatic pinner/nailer; slower if you have to rely on clamps exclusively. Regardless, the process will be the same.

First, glue one plywood piece to one of the rabbets in the cherry edge. Make sure you have a nice tight joint. For this, white or yellow glue is fine. Next, glue the end and intermediate ribs in place, spacing them about a foot apart. For this cross-grain gluing, use polyurethane glue. Also, use glue where the end of each rib butts to the solid cherry. Lastly, glue the second piece of plywood as before.

Even if you use a pneumatic pinner, clamp the ends and the rabbet joints. Also, keep your nails out of the way of the 45-degree end cuts to come later. Don't forget to pin or clamp the pine pieces on both sides of the shelf. Continue assembling panels until all four horizontal and two vertical panels are done.

After the glue has dried, sand or use a scraper to flush up the surfaces where the plywood and front edge meet. Now you are almost ready to cut the big chamfer on the front edge of each panel. Carefully mark each

panel so that the reinforced plywood back edge is facing up for correct orientation to the chamfer. Next, use your router to form a 1/4" radius on what will be the outside edge of each panel's front edge. When done, cut the chamfer using your table saw so the cut blends into the radius detail.

The ends of each panel now get a cross-grain miter cut. Again, before cutting, note the orientation of the cut relative to the reinforced plywood. It's best to put the three parts that make up one unit together, mark the edges to be glued later and — for the horizontal pieces — the end which is strictly decorative. Make the cut with a table saw, sliding compound miter saw or a radial arm saw.

The last bit of preparation before assembly is to cut biscuit joints in the miters that will be glued together.

Assembly

Dry assemble the parts to check fittings and figure out a clamping strategy. I fashioned an "I-beam" type piece from 3/4" plywood that 1) held the long panels up and in position while assembling; 2) gave me a surface to clamp to that didn't require long

SCHEDULE OF MATERIALS: MAGIC SHELVES

No.	Item	Dimensions T W L	Material
2	Front edges	1 3/8" x 2" x 24"	Cherry
1	Front edge	1 3/8" x 2" x 78"	Cherry
1	Front edge	1 3/8" x 2" x 70"	Cherry
1	Front edge	1 3/8" x 2" x 61"	Cherry
1	Front edge	1 3/8" x 2" x 55"	Cherry
2	Shelf skins	1/4" x 9 1/2" x 55 5/8"	Cherry ply
2	Shelf skins	1/4" x 9 1/2" x 70 5/8"	Cherry ply
2	Shelf skins	1/4" x 9 1/2" x 78 5/8"	Cherry ply
2	Shelf skins	1/4" x 9 1/2" x 61 5/8"	Cherry ply
4	Shelf skins	1/4" x 9 1/2" x 24 5/8"	Cherry ply
12	End bldups	7/8" x 2 1/2" x 9 1/8"	Pine
30	Bldups	7/8" x 1 1/2" x 7 5/8"	Pine

Approx. 22' hardwood cleat material 7/8" x 2 1/8".



The long panels are joined to the short vertical panels using biscuits in the miter joint. The biscuits strengthen the joint and help hold alignment during glue up (**left**).

What could be an unwieldy glue-up is simplified using an "I-beam" shaped plywood fixture. The fixture clamps to the long panels, holding them in place, provides a clamping surface for pulling the end in position and helps keep the whole assembly square (**bottom left**).

The shelves hang on cleats that are carefully positioned and then screwed to the wall (**below**).



clamps; and 3) went a long way toward holding the entire assembly square during the process.

After the glue has set up and before removing the "I-beam" brace, make a simple support that attaches to the back side that will support the long "legs" through the rest of the work and until you install the units. Just make simple blocks that can be screwed into one of the interior pine pieces, then screw a brace between them.

Now cap the other long ends that are chamfered with some homemade cherry

"vener." Slice four pieces that are about $\frac{1}{16}$ " thick off a piece of cherry of sufficient width. Size the pieces so that there is about $\frac{1}{8}$ " extra all around when applied. A simple way to attach these is to use contact cement. Trim and sand off the overhang after applying.

In preparation for installation, cut lengths of a sound hardwood, such as oak or maple, milled to the exact thickness of the opening in the back of each long shelf. The width should be about $\frac{1}{8}$ " less than the depth of the opening. These pieces will be securely

fastened to the wall studs and positioned so that the openings in the rear of the shelves will sleeve over them. Screws will then be used to fasten each shelf to its wall cleat. You can pre-drill and countersink holes in the top rear edge of shelf, spaced about 14" apart. Now you understand why the plastic laminate or metal was used to reinforce the thin plywood. Wait until you are ready to install the shelves before drilling pilot holes in the cleats. That way, you can mount the cleats on the wall, then position and mark the locations for pilot holes.

To complete the shop portion of this project, thoroughly sand and be careful to remove any dried glue, especially near the miter joints. Sand to 150 grit. For this project, I clear coated the units with lacquer. Just take the time to sand between coats to help achieve a nice, smooth finish.

Ultimately, this is a simple project that is a terrific primer on torsion box construction and produces a striking end result. You might say that for all but beginning woodworkers, it's a project you can ACE. **PW**

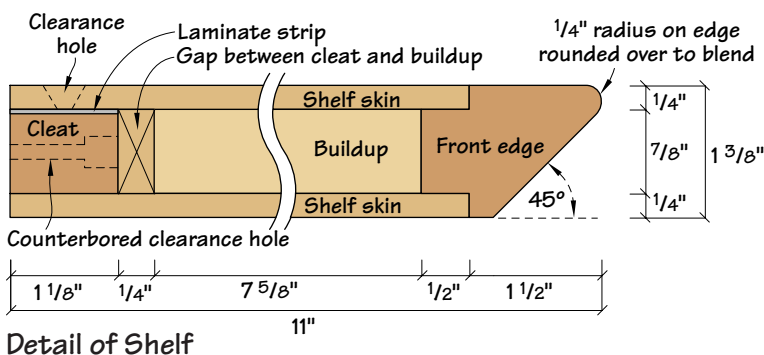

Floating Shelves

Learn to wrap the grain around a miter joint. You don't need special clamps, just some packing tape.

Open any contemporary furniture catalog, and you'll see shelves for sale that look like they're floating in mid-wall. The designers have clearly mastered the trick to make these shelves float (usually a French cleat), but they haven't mastered how to make these shelves look like something more than scrap architectural moulding.

By using a couple furniture-making tricks you can build floating shelves that look worlds better than those off-the-rack racks.

Match the Grain

These shelves have grain that wraps around the miters at the two front corners of the unit. It's easy to do and impressive when you are done.

Each unit is comprised of a front and two sides that are cut from a single board that is $3\frac{3}{4}$ " wide and about 56" long. The sides are sawn free from the front and mitered. Then you glue the sides back to the front piece, screw a cleat between the

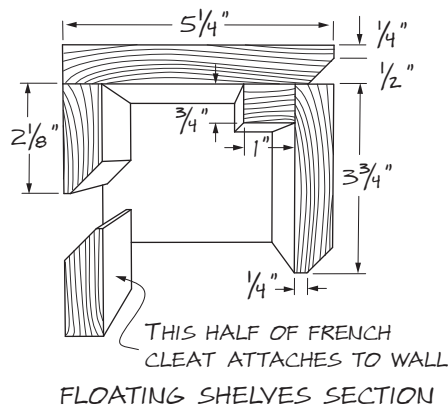

ILLUSTRATION BY ROBERT W. LANG



PHOTO BY THE AUTHOR

Simple furniture-making tricks make this project easy to build. Packing tape clamps your miters closed, and a French cleat system suspends the shelves on the wall.

sides and screw the top in place. Then you hang the whole thing on a cleat screwed to the wall.

Chamfers and Miters

After milling all your material to $\frac{3}{4}$ " thick, take the piece that will make the front and sides and chamfer its bottom edge. The goal is to leave a $\frac{1}{4}$ "-wide flat on the board's bottom edge.

Now separate the sides from the front. I first cut the sides free with straight 90° cuts. A miter saw will do, though a hand saw or band saw will remove less material for a better grain match. Then miter the mating corners using a miter saw and take care not to remove too much material.

Gluing up the sides and front is a job for packing tape. Press the tips of your miters together and tape over the outside of the miters. Then apply glue to the inside of the miters, fold the joints together and use more packing tape to hold the miters closed until the glue dries.

Then cut one French cleat to finished length, chamfer one long edge and screw it between the

sides (I used pocket screws). Face the chamfer toward the front of the unit.

More Chamfers and Screws

Now cut your top to finished size. Chamfer its sides and front edge with the same setup you used for the base. The top is attached to the base with a $\frac{3}{4}$ " x 1" cleat. Glue this cleat to the backside of your front piece. Then screw the top to the cleat from underneath. The last assembly step is to make the French cleat that screws to the wall. It also has a chamfer on one long edge.

Finishing and Hanging Details

I wiped on boiled linseed oil, left the project in the sun for an afternoon to darken the cherry and then allowed the oil to cure for a week. Finally, I added a protective topcoat of aerosol lacquer.

Hang your shelving unit by screwing the free cleat to your wall. Then just drop the unit on the cleat and your job is done. **WM**

— Christopher Schwarz

Floating Shelves

NO.	PART	SIZES (INCHES)			MATERIAL	NOTES
		T	W	L		
□ 1	Front	$\frac{3}{4}$	$3\frac{3}{4}$	44	Cherry	Chamfer bottom edge
□ 2	Sides	$\frac{3}{4}$	$3\frac{3}{4}$	$5\frac{1}{4}$	Cherry	Chamfer bottom edge
□ 1	Top	$\frac{3}{4}$	$5\frac{1}{4}$	44	Cherry	Chamfer three edges
□ 1	Top cleat	$\frac{3}{4}$	1	$42\frac{1}{2}$	Cherry	Glue to front; screw to top
□ 2	French cleats	$\frac{3}{4}$	$2\frac{3}{16}$ *	$42\frac{1}{2}$	Cherry	45° bevel on one long edge

* Dimension is slightly oversized. Trim to fit.



All-in-one

Cabinet

FOR THE SMALL SHOP

This shop cabinet squeezes 13 cubic feet of tool storage into less than 3 square feet of floor space.

If you're like most woodworkers, your shop is packed to the gills with tools, tooling and accessories. Storing power tools on open shelves is no good; dust will get into the windings and shorten the life of your motors. You need an enclosed cabinet, and you need one that takes up less floor space than a band saw. This cabinet has a place to store routers, all the bits a woodworker could need and other accessories such as edge guides, bases and template guides. There's also room for other tools such as jigsaws, sanders, biscuit joiners and even a portable planer.

Build the Case

Before cutting the plywood, check out the optimization diagram on our web site (www.popwood.com), which shows you how to lay out the parts on two sheets of plywood. After the parts are cut to size, cut $\frac{1}{2}$ " x $\frac{3}{4}$ " rabbets on the ends of the sides to hold the top and bottom pieces. Unless your shop has high ceilings, you'll need to cut the rabbets with a plunge router, straight bit and an edge guide. First set the router for the finished depth using your turret depth stop. Now raise the bit halfway and make a pass that defines the shoulder of the rabbet. Now climb cut (which is basically routing in reverse, moving the router backwards) the waste out to the edge of the board. Finally, plunge to the full depth of your rabbet and repeat the above procedure.

The next step is to cut the $\frac{1}{4}$ " x $\frac{3}{4}$ " dados in the sides. Mark the location of the dado and make a simple jig to rout it. The jig uses a bearing-on-top straight bit to guide against the edges of the jig. To make the jig, take the fixed shelf and place two strips of plywood against it on a flat surface. Place all this on top of two cross pieces on either end of the strips and glue and nail them in place. Leave a little room (about $\frac{1}{2}$ ") across the length of the dado cut to adjust the jig. Clamp the jig on the marked lines and rout the dado in two passes. Finish machining the sides by cutting the $\frac{1}{2}$ " x $\frac{1}{4}$ " rabbet for the back on the back edge of both sides, top and bottom. (If the cabinet won't be attached to the wall, use a thicker back for stability.) Check the top, bottom and fixed shelf for a good fit, then glue and nail or screw the cabinet together. Fit the back and set it aside. Place the case on a flat work surface and add iron-on edging. Finish the case by gluing and nailing the hanging rail into the top of the case, flush with the rabbet in the back.



Here's the simple jig to rout the dados. It uses a bearing-on-top straight bit to guide against the edges of the jig. Clamp the jig right on the marked lines and rout the dado.

by Jim Stuard

Comments or questions? Contact Jim at 513-531-2690 ext. 348
or JimS@FWPubs.com

Build the Base

Now comes the adjustable base. When I made custom cabinetry, we often added an adjustable-height base to cabinets so we could compensate for uneven floors or walls. The base is a simple plywood rectangle. You attach the adjustable feet to the inside corners and drill holes in the case above the feet. This allows you to adjust the base with a screwdriver while the cabinet is in place.

The base itself is a simple mitered frame, with biscuits added at the miters. Cut the miters, then glue and clamp the base together. Make sure the base is square by measuring across the corners.

While the glue dries, cut out the blocks that hold the adjustable feet. They're just $1\frac{1}{2}$ " x $1\frac{1}{2}$ " x $3\frac{1}{4}$ " blocks. Drill a centered, $\frac{7}{16}$ " hole through the length of the block for a T-nut. Drill holes at right angles to one another in the block that will be used to screw the blocks to the base. Hammer



Use screws and glue to attach the levelers to the inside corners of the base frame. The top of the block (the end opposite the foot) should be flush with the top edge of the base frame.

in the T-nuts. With the feet threaded into the blocks, the entire assembly is about 4" long. It should flush up with the top and bottom of the base frame.

Now it's time to attach the base. Cut out four $\frac{3}{4}$ " x $\frac{3}{4}$ " cleats that fit between the levelers and drill mounting holes in the cleats for attaching the case bottom. Screw them in place about $\frac{1}{32}$ " down from the top edge of the base. Make sure to Position the base on the bottom. Temporarily screw the base in place with four $1\frac{1}{4}$ " screws.



With the case on its back, take two hand screws and attach them to the back lip of the case, $\frac{1}{4}$ " in from the back. This provides a little offset for the moulding on our walls. If you have larger base moulding where you are, make the base a little taller or less deep to accommodate the larger moulding. Place the base up against the case bottom. Center it on the bottom and temporarily screw it into place with four $1\frac{1}{4}$ " screws.

Take out all the feet and use a pencil to mark the location of the top of the leveler hole. Drill the holes using a piece of scrap to back up the hole or you'll tear out the veneer on the inside of the case bottom. When you re-attach the base, you'll be able to adjust the levelers using a straight-bladed screwdriver.

Build the Doors

The doors are plywood slabs with a mitered moulding nailed to the edges. The moulding is a $\frac{3}{16}$ " x $1\frac{3}{16}$ " solid wood edge with a bullnose routed on the front (see diagram). The bullnose is referred to as a cockbead, which is a common detail on period furniture from the 18th and 19th centuries. It's an easy way to dress up a door or drawer front.

After the edging's been applied, it's

impossible to sand into the corners, so begin making the doors by finish sanding the fronts of the doors and drawer fronts. Next, attach the moulding. First apply two opposite pieces, then fit and attach the last two pieces.

Use a sharp pencil to mark the location of the miter cuts. Place the piece on the miter saw and cut to the line. You don't always get the cut right the first

time. Make your cut a little long and nibble away at the miter until you get a snug fit, then glue and nail the edges in place. We use Accuset's micropinner to attach the mouldings. The 23-gauge pins don't split the edge, and they leave a hole about the size of a period on this page. Putty the holes if you like. Rout off any overhang on the back side with a router and straight bit. Finish sand the backs.



After making the stock according to the diagram, take a piece and cut a miter on one end. Be sure to make the first cut with the bullnose up. This isn't important for the first two edges, but it's very important for the last two. Use a piece of scrap with a miter cut on both ends to test the fit of the miters.

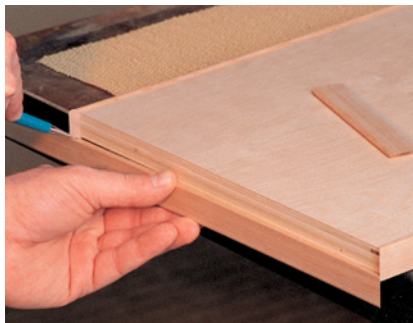

When fitting the second set of edges, start by cutting the miter on one end. Flip the edge over and place what will be the bottom edge of the miter into the miter on the right. Gently press the flat edge up against the other miter. Mark the location of the miter and make the cut.



Drill the holes for the hinge cups on your drill press. Always make a test piece with a hinge and mounting plate to test your setup.



Take out all the feet and use a pencil to mark the location of the top of the leveler hole. Remove the base and drill 1/2" holes into the case bottom.

SUPPLIES

Lee Valley Tools

800-871-8158 • www.leevalley.com

4-107° Full overlay hinges, 00B10.01

1-14" Full ext. drawer slides, 02K10.14

4-4" Swivel leveler, 01S06.04

4-3/8"-16 T-nuts (10 pc.), 00N22.24

5-4" Wire pulls, 01W78.04

1-Coat hook, 00W80.01

24-Shelf pins (50pc.), 94Z03.02

1-25' Maple edge banding, 41A05.01

2-25mm x 15mm hinges, 00D30.08

8-#1 x 3/8" screws (10pc.), 91Z01.02

This is offered by Lee Valley as a package priced at \$72. Ask for item #05D1510

Note: The screws supplied with the hinges use a #1 (square) drive. You'll need a small #1 square drive bit.

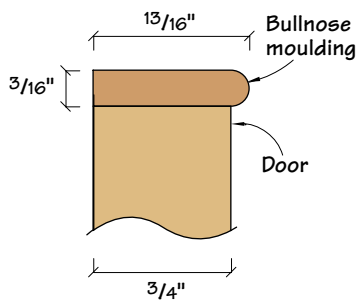

Bullnose Moulding

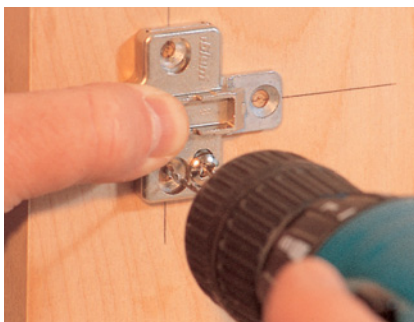

Lay the plate on the marks and drill pilot holes into the cabinet.



You're ready to hang the doors. The cups for European cabinet hinges are usually 35mm or really close to $1\frac{3}{8}$ ".

Using the instructions supplied with the hinges, derive a drilling location for the hinge cup. I've always drilled hinge cups about 3" or 4" in from the top and bottom of the door. This leaves enough room to adjust the hinge when mounted. The first thing is to drill the hinge cup holes. Set your drill press to drill the holes

a little deeper than the cup.

Now transfer the layout holes to the door on the cabinet. Attach the mounting plate and screw the hinges in place. European hinges can be adjusted in three dimensions: in-out, up-down and left-right. When the cabinet is level and plumb, adjust the hinges to make the doors even.

Build the Router Bit Drawer



After attaching the slide to the drawer, mark the location of the cabinet part of the slide on the cabinet side. Use a framing square to run a line back from this mark and mount the slide $\frac{1}{16}$ " back from the front of the cabinet.



The drawer uses standard construction. Cut $\frac{1}{4}$ " x $\frac{1}{2}$ " rabbets on the ends of the sides. Cut a $\frac{1}{4}$ " x $\frac{1}{4}$ " groove in the bottom inside edges of all the parts to hold the bottom. Glue and nail the drawer together with the bottom set into the groove.

After the glue is dry, take apart the commercial drawer slides, scribe a line on the sides and attach the small part of the slide to the drawer box. Make sure it's flush to the front of the drawer box. Measure from the mounting line and add $\frac{3}{4}$ " to that for the lid, hinges and gap. Measure that distance down from the inside, underneath the fixed shelf. Mark the location and mount the slide. The slides have two different mounting holes. The drawer has slots that allow up and down adjustment, and the cabinet parts have slots that allow forward/backward adjustment. Insert the drawer into the slides on the cabinet.

Before mounting the front on the drawer box, nail two finish nails through the front of the drawer box until they just protrude from the outside. Place the front against the drawer box and space it so the gaps on the top and bottom are equal. Push the front against the nails in the drawer box and gently push the drawer out. Drill some clearance holes and attach the front.

Now nail on the drawer lid's back rail and attach the lid with two hinges. Drill a 1" hole in the lid so you can lift it easily. Cut

Position the drawer front and place a couple of clamps on the drawer box to hold it in place. Drill countersunk clearance holes into the drawer box and attach the front with 1" screws.



Drill the $\frac{1}{2}$ " and $\frac{1}{4}$ " holes. Nail in a couple of rails on the inside of the drawer and simply drop the panels in place. The panel for $\frac{1}{2}$ "-shank bits is drilled all the way through and the panel for $\frac{1}{4}$ "-shank bits is drilled down $\frac{5}{8}$ ".

out, drill and attach the two router storage inserts.

Finish up the project by drilling a series of 7mm holes for the shelf pins. Make a template from scrap for this. Lee Valley sells metal sleeves for the shelf pins, but I deemed them unnecessary. You could probably get away with using a $\frac{1}{4}$ " bit to make these holes, but it makes the pins fit a little sloppy. Attach the back with #6 x $\frac{1}{2}$ " flat-head screws. Check the fit of all the doors, drawer and shelves, then disassemble all the loose parts for sanding. Apply three coats of clear finish and reassemble all the parts. **PW**

Use a stop collar on your drill bit when drilling holes for the shelf pins. I made this drilling jig from shop scrap.



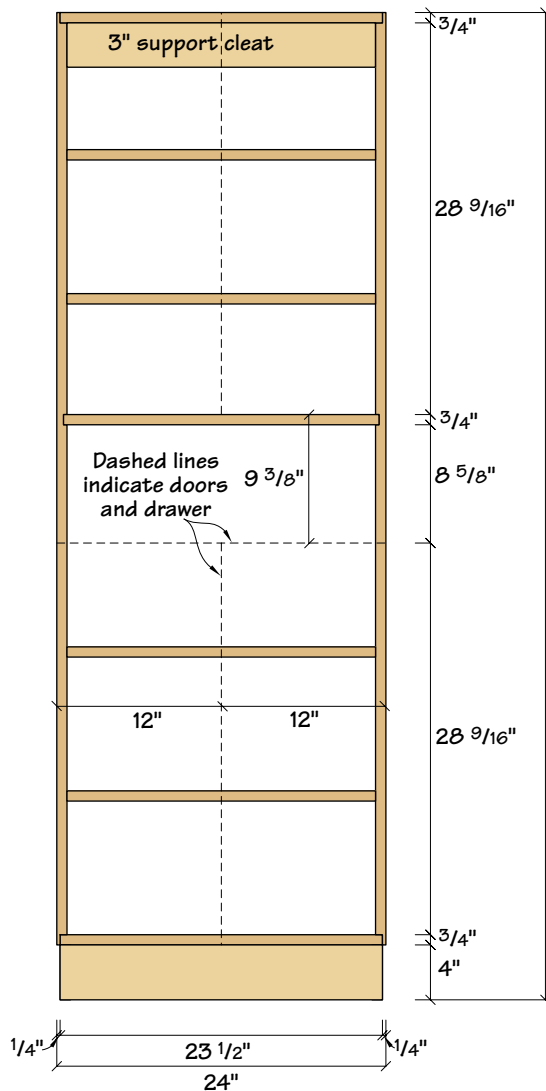

Elevation

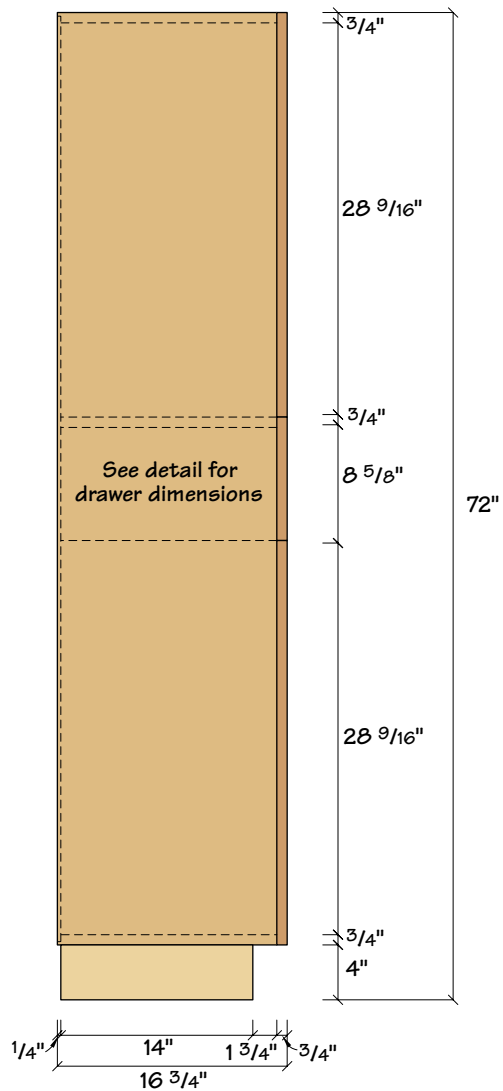

Profile

SHOP STORAGE CABINET

No.	Item	Dimensions T W L	Material
2	Sides	3/4" x 16" x 68"	Birch ply
2	Top and bottom	3/4" x 16" x 23 1/2"	Birch ply
1	Fixed shelf	3/4" x 15 3/4" x 23"	Birch ply
4	Shelves	3/4" x 15 1/2" x 22 1/2"	Birch ply
1	Back	1/4" x 23 1/2" x 67 1/2"	Birch ply
4	Doors*	3/4" x 12" x 29 1/4"	Birch ply
2	Base front and back	3/4" x 4" x 23 1/2"	Birch ply
2	Base sides	3/4" x 4" x 14"	Birch ply
1	Cleats for base	3/4" x 3/4" x 96"	Solid wood
4	Leveler blocks	1 1/2" x 1 1/2" x 3 1/4"	Solid wood
1	Support cleat	3/4" x 3" x 23 1/2"	Birch ply
1	Drawer front*	3/4" x 9 3/8" x 24"	Birch ply
2	Drawer sides	1/2" x 8" x 15 1/2"	Baltic birch
2	Drawer front and back	1/2" x 8" x 21"	Baltic birch
1	Drawer bottom	1/4" x 15" x 21"	Baltic birch
2	Drawer rails	1/2" x 1" x 20 1/2"	Baltic birch
1	Drawer insert slider	3/4" x 14 1/2" x 12"	Birch ply
1	Drawer lid	1/2" x 12 1/2" x 21 1/2"	Baltic birch
1	Lid back rail	1/2" x 3" x 21 1/2"	Baltic birch

* Finished size with bullnose edging attached

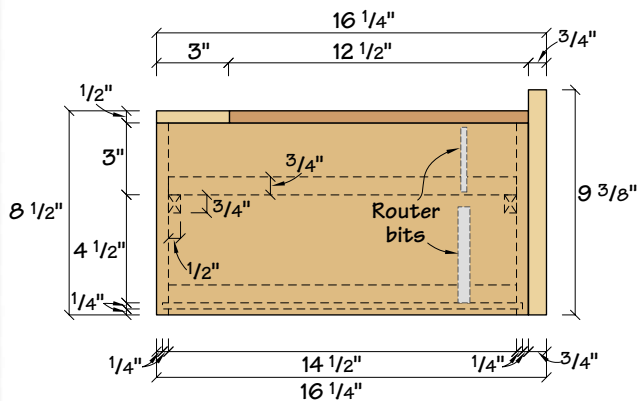

Profile of Drawer

Get More Great Woodworking Resources!

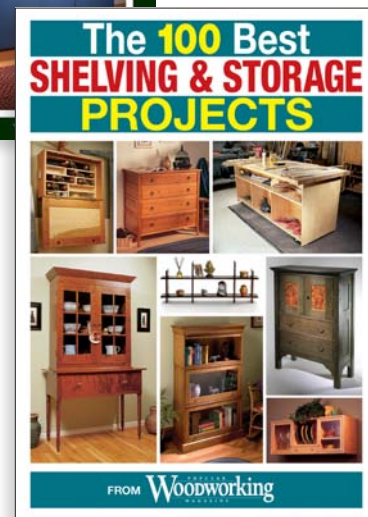

Your free download is excerpted from the **April 2000** and **April 2001** issues of *Popular Woodworking* and the **Spring 2009** issue of *Woodworking Magazine* and is just a sample of the great shelving projects you can find in the ShopWoodworking.com store. Buy more projects today, and continue building your knowledge!

**Buy the full contents today,
and continue building
your knowledge!**